

DEMA *TITAN*[™] II WAREWASH CONTROL T.812 & T.813 SERIES

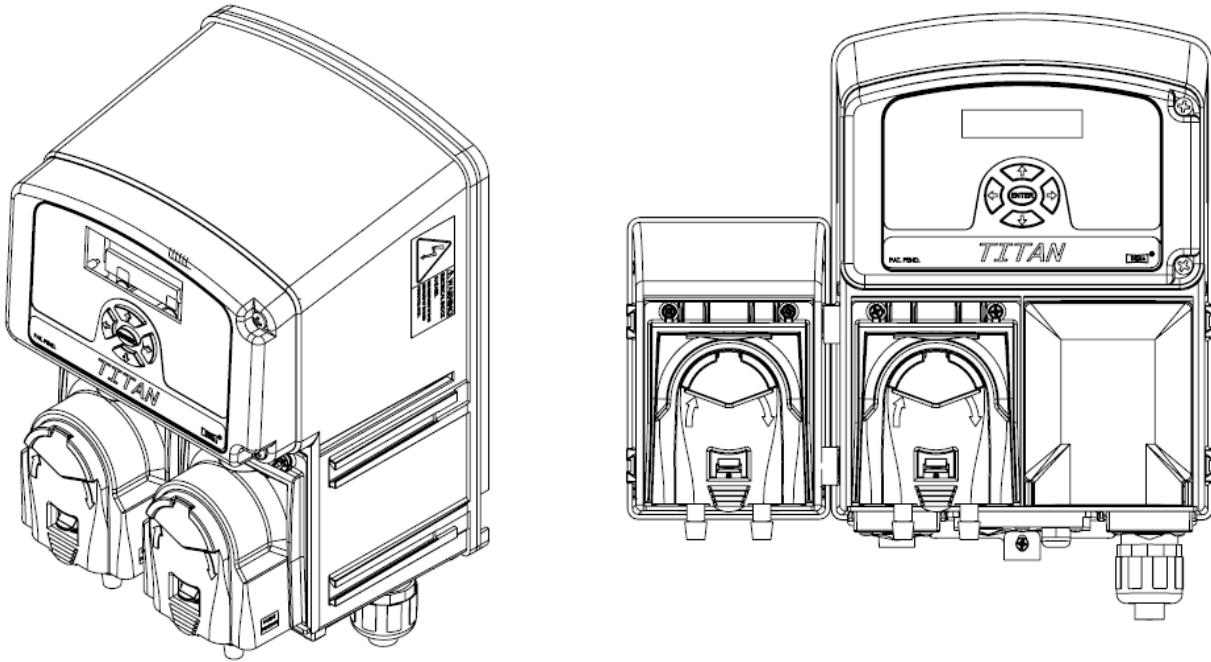

Overview

The *Titan*[™] ware wash system controls all chemical delivery functions for dish machines and similar warewash applications. The system has an advanced power supply that will accept 100V–250V 50/60Hz. The *Titan*[™] responds to detergent and rinse triggers in the range of 20V–500V 50/60Hz. The *Titan*[™] has been designed for simple installation, set up, and operation. The Titan has an Auto Switchover feature that allows automatic switching from Concentration to Probeless. This Auto Switchover feature virtually eliminates service calls.

Warnings



Installation of DEMA products must meet all applicable electrical codes and regulations established by national, city, county, parish, provincial or other agencies. It is possible that electrical codes and regulations require that a certified electrical contractor or engineer perform the electrical installation. For questions, contact a certified electrician.



ALL ELECTRICAL POWER MUST BE TURNED OFF TO THE DISPENSER AND TO THE APPLIED MACHINE.



All installations must conform to local plumbing codes and use approved backflow prevention devices. A pressure indicating tee is to be installed with existing faucets according to local plumbing codes in the state of Wisconsin and any other state that requires the use of a pressure indicating tee.



ALWAYS WEAR PROTECTIVE CLOTHING AND EYEWEAR WHEN WORKING WITH CHEMICAL PRODUCTS.

Specifications

Packing List

PART NO.	DESCRIPTION	T-812-LL	T-812-DL	T-813-LLL	T-813-DLL
904-8T	Rinse Check Valve	1	1	1	1
80-55	Bulkhead Fitting with Liquid Feed Injection Elbow ¼"	1		1	
58-5	Overflow Elbow Kit		1		1
81-16-1	Tie Wrap 8" lg.	5	5	8	8
81-312-3	Pickup Tube Assembly 17"	2	1	3	2
81-182-1	¼" x ¼" JG Union	4	2	6	4
25-68-20	20 ft. x 1/8"ID LDPE (detergent)	1	1	1	1
100-12-SV1	16 ft. x 1/16"ID Vinyl (rinse/san)	1	1	2	2
C-12V1K	Conductivity Cell	1	1	1	1
904-8KY	Sanitizer Check Valve			1	1

Operational Requirements

For Indoor Use Only		
Main Power	100 VAC – 250 VAC	50/60 Hz 1.5 A
Trigger Signals	20V – 500V	50/60 Hz
Motors/Solenoid Valves	24VDC	
Case Material	ABS	
Weight	3.8 kg	8.5 lbs
Max. Altitude	2000 M	6500 ft
Environmental Temp	0-40°C	32-104°F
Installation Category	II	
Pollution Category	II	

Overall Size

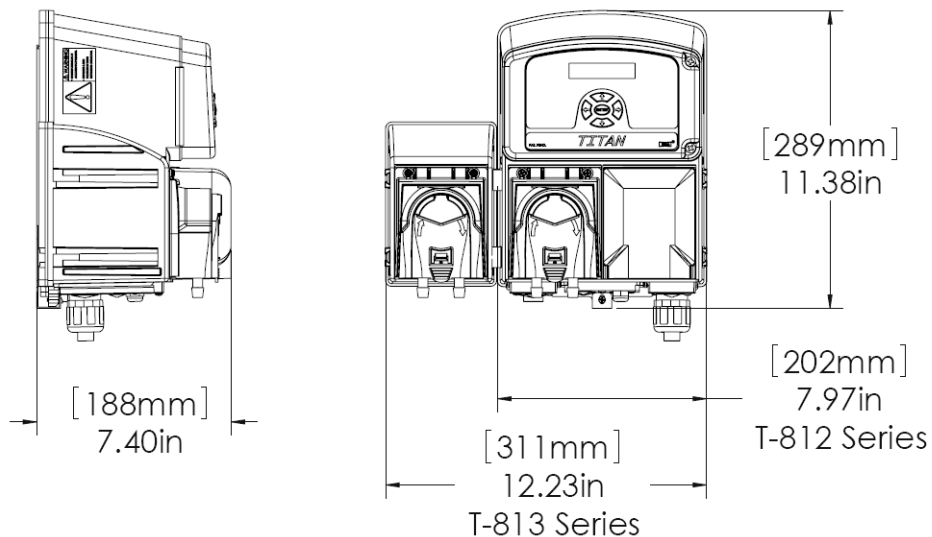

Parts List

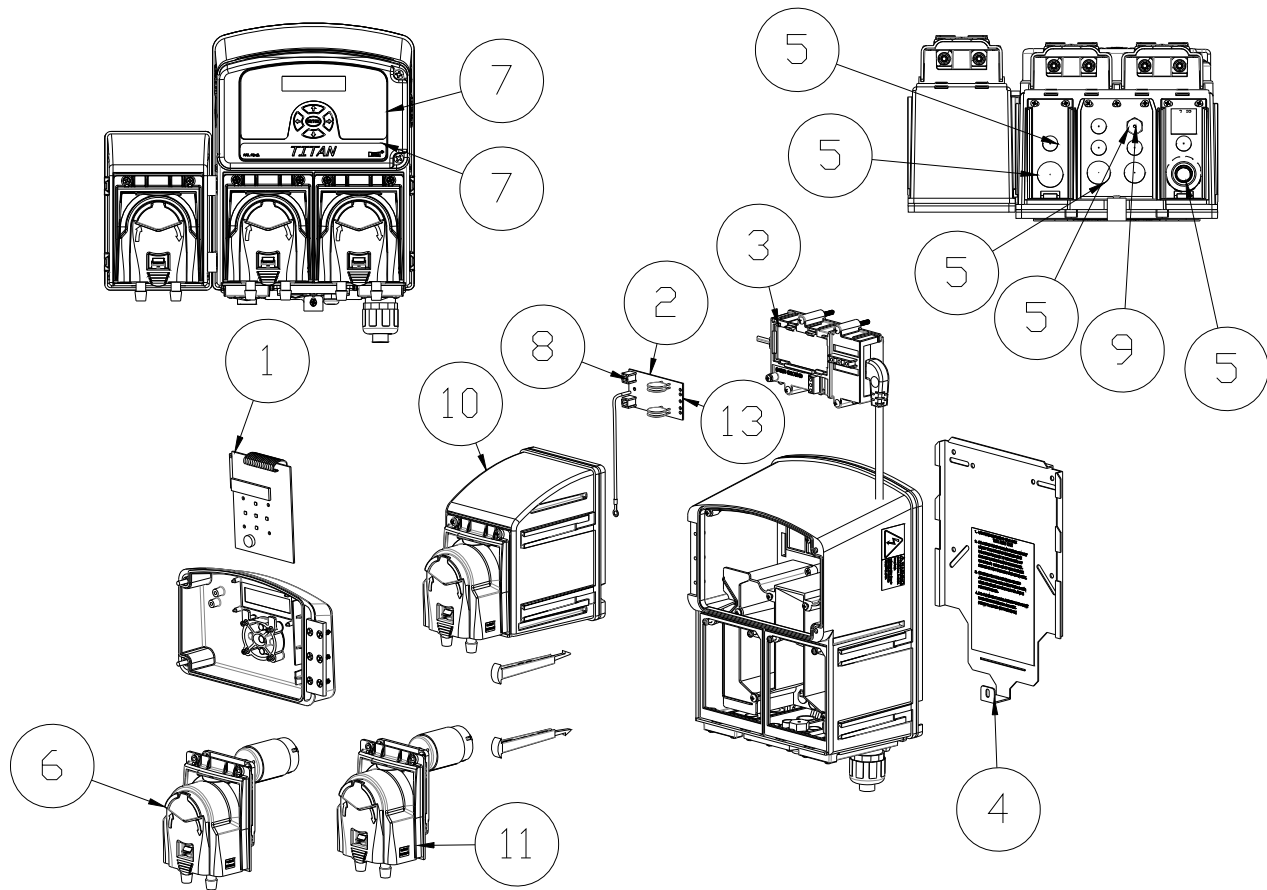

NO.	QTY.	DEMA NO.	DESCRIPTION
1	1	81-118-31	CONTROL BOARD AND DISPLAY ASSY.
2	1	81-118-11-2	TRIGGER BOARD WITH TERMINAL BLOCK
3	1	81-118-35	POWER SUPPLY (includes 84-125-7 power supply cable)
4	1	81-187-1	MOUNTING BRACKET
5	1	81-359-1	TITAN II HOLE PLUG AND FITTING KIT
6	1	81-118-29-2	RINSE PUMP AND MOTORASSEMBLY - 15 RPM
7	1	81-360-1	TITAN II LABEL KIT
8	1	81-118-12	TRIGGER CABLE REPLACEMENT KIT
9	1	81-181-2	PROBE CABLE - 15' Lg.
10	1	81-118-18	PUMP MODULE ASSY. - SANITIZER (For T-812-LLL, T-812-DLL)
11	1	81-118-29-1	MOTOR AND DETERGENT PUMP HEAD ASSEMBLY - 60 RPM
12	1	81-118-19	SOLENOID VALVE KIT (For T-811-D, T-812-DL, T-813-DLL)
13	1	81-330-1	TRIGGER/POWER CABLE
14	NOT SHOWN	82-23-1	MAGNETIC FIELD READER KIT (SEE PAGE 5 FOR INFO)
15	NOT SHOWN	82-28-1	INDUCTIVE PROBE KIT (SEE PAGE 5 FOR INFO)
16	NOT SHOWN	84-65-46	PRODUCT ALARM SENSOR KIT (SEE PG 14 FOR INFO)

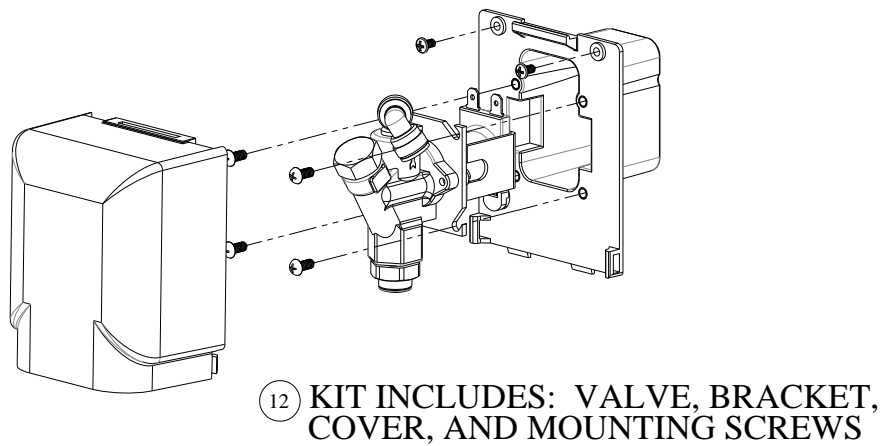
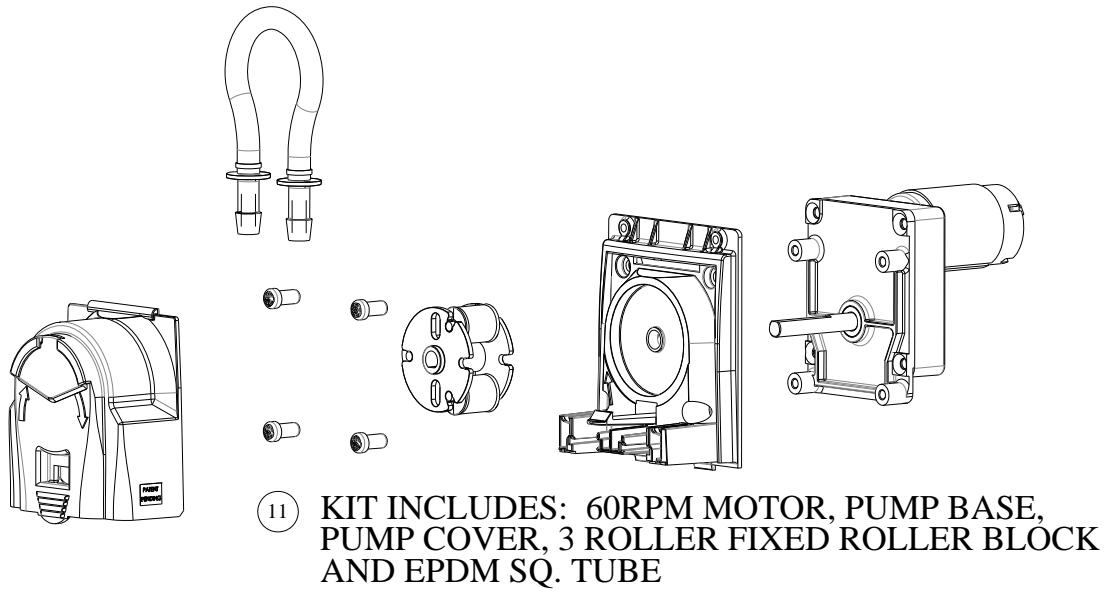
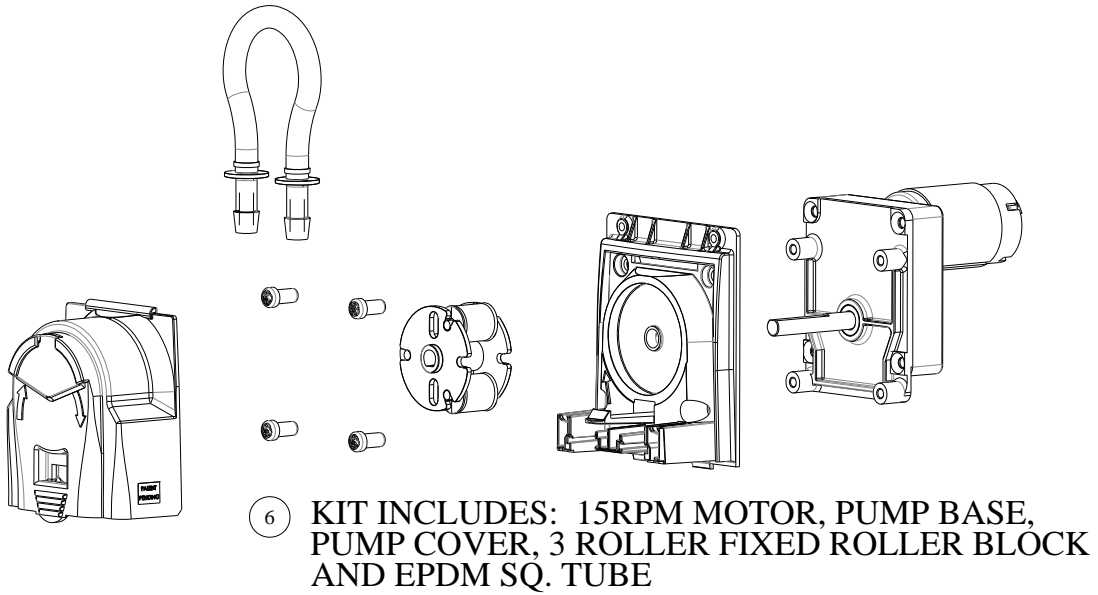

Installation

WARNING: Installation of DEMA products must meet all applicable electrical codes and regulations established by national, city, county, parish, provincial or other agencies. It is possible that electrical codes and regulations require that a certified electrical contractor or engineer perform the electrical installation. For questions, contact a certified electrician.

ALL ELECTRICAL POWER MUST BE TURNED OFF TO THE HEATING ELEMENTS AND DISH MACHINE PRIOR TO BEGINNING INSTALLATION.

UNIT MUST BE PROPERLY GROUNDED (EARTHED).

Dish Room Survey

Prior to installation, take a complete survey of the dish room. Determine the desired placement of the Titan™ and chemicals. Also, determine how the electrical connections will be made. Main power and trigger cords must run through a nonmetallic ½” conduit system.

Mounting the Titan

1. Remove the Mounting Bracket from the dispenser.
2. Mount the bracket in an appropriate place on the wall, away from splashing and steam from the machine.
3. Slide the dispenser onto the bracket and attach the secure screw on the bottom of the dispenser.

Setting up the Titan and the Dish Machine

1. Locate the electrical connection point. The input power may be 100V – 250V 50/60Hz. Check with the manufacturer of the machine to determine if there are dedicated terminals available for this installation.
2. Properly ground the dispenser to Earth ground.
3. If the Titan™ will be operating in the concentration mode locate the proper position for the DEMA C-12VIK probe or the Inductive Probe (82.28.1) in the wash tank. The probe must be installed below the water level, normally 1”-2” from the bottom of the tank and must be kept away from heating elements, pump intake, drains and incoming water supply.
4. Install the detergent injection bulkhead (80-55) fitting above the probe (if a probe is used) to obtain a rapid reading of all chemicals entering the wash tank.
5. Install the rinse line injection fitting (904-8T) into the rinse line tap provided by the manufacturer of the machine. If a tap is not provided, follow the manufacturer’s recommendations for installing this fitting.
6. Install the sanitizer injection fitting (904-8KY) (if sanitizer is used) into the rinse line tap provided by the manufacturer of the machine. If a tap is not provided follow the manufacturer’s recommendations for installing this fitting.

Connecting the Chemical Tubing to the Titan

1. After mounting the dispenser, measure the length of tubing needed to go from the dispenser to the chemical containers. The detergent tubing (25.68.20) is opaque in color and has a larger inside diameter than the rinse and sanitizer tubing (100.12.SV1) which is clear in color and has a small inside diameter.
2. Cut the tubing to the length required and, if desired, place the pickup tube on the tubing before placing in the chemical container.
3. Measure the length of tubing needed to go from the dispenser to the chemical injection point on the machine. Cut the tubing to the length required to reach the chemical injection point on the machine.

Wiring the Titan to the Dish Machine

The following diagram is included to help to install the wires in the correct places for proper power for the unit.



WARNING: For safety purposes disconnect main power to the dish machine. Connect power to the Titan per the dish machine manufacturer’s recommendations.
UNIT MUST BE GROUNDED (EARTHED).

Magnetic Field Sensors - If trigger connection points cannot be established, the magnetic field sensors (82.23.1) may be used in place of the trigger board and cable. The magnetic field sensors connect directly to the control board in the trigger wire spots as shown on the wiring diagram. The magnetic field sensors can be placed on wash motors or rinse valves to measure a magnetic field when the motors or valves are activated which will trigger the proper pump or valve on the dispenser.

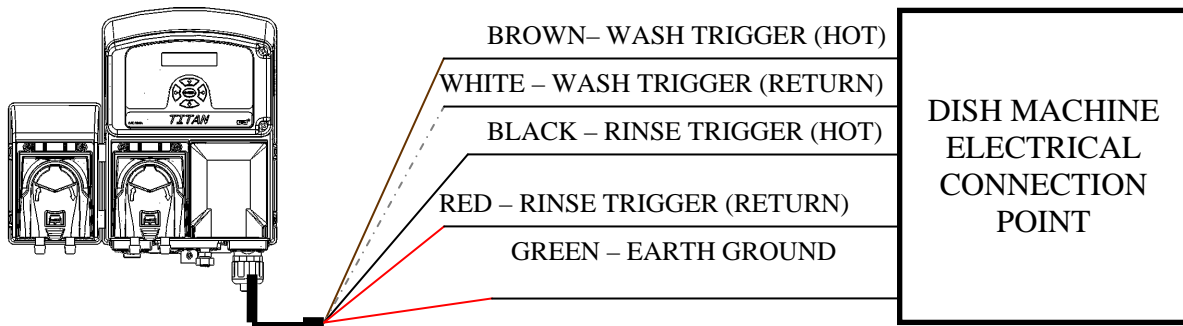

The following steps will help to insure the proper wiring of the unit. The unit should be triggered to power on from the dish machine that it is being used in conjunction with. DEMA Engineering does not recommend powering the unit separately from the dish machine. The following three steps will insure that the unit only receives power when it is necessary to have power to run the setup that is programmed in the unit.

1. Connect power to the Titan™ per the dish machine manufacturer's recommendations. Constant power should be supplied to the Titan™ anytime the dish machine power is on.
Power to the Titan™ should not be supplied via the wash motor on the dish machine.
2. Connect the detergent trigger (brown and white wires) to the dish machine per the dish machine manufacturer's recommendations. The Titan™ should receive a detergent trigger any time the wash motor is running.
3. Connect the rinse trigger (black and red wires) to the dish machine per the dish machine manufacturer's recommendations. The Titan™ should receive a rinse trigger any time the rinse solenoid is powered.

The following is an internal wiring diagram for the unit.

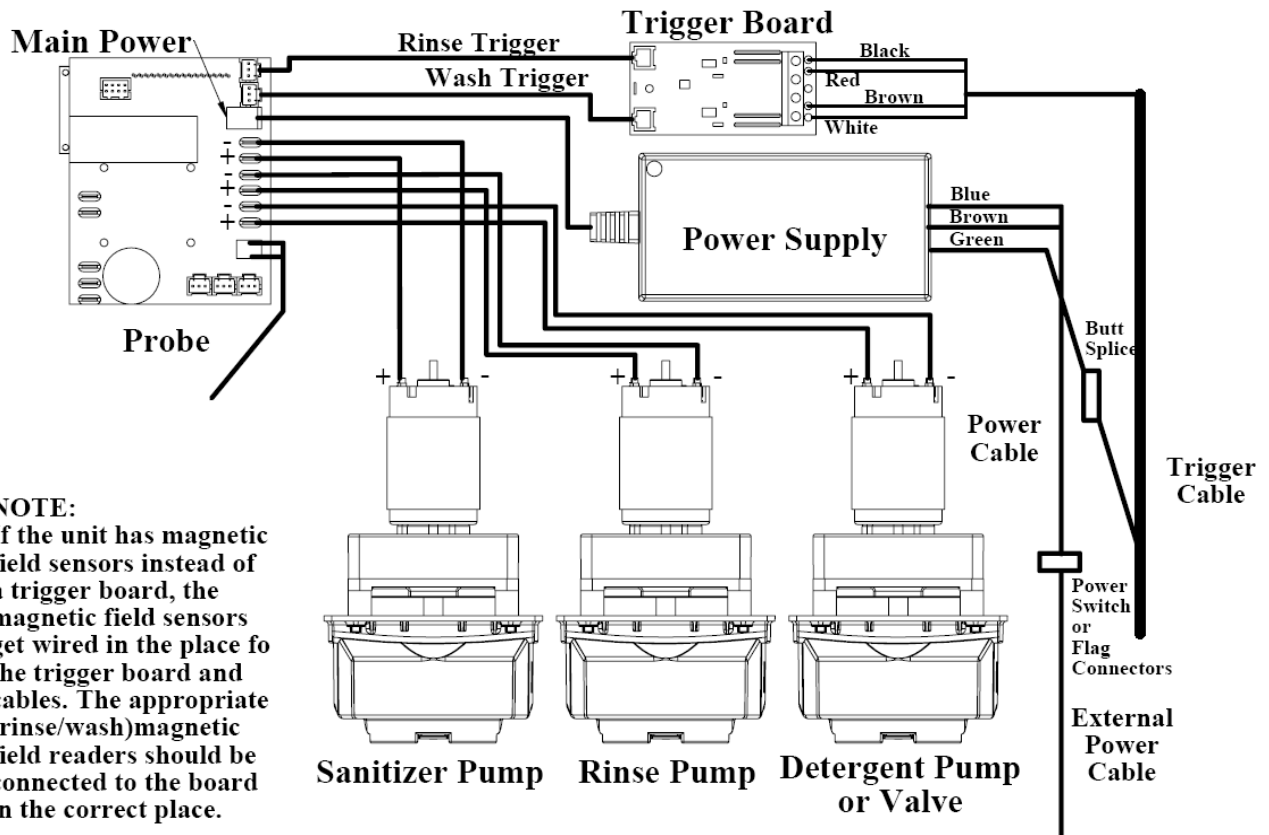

Initial Programming

Following in **bold** is the initial programming menu as it will appear in the display window. Pressing any key will display the company name and illuminate the backlight. Use **↑** and **↓** to step between the options in the first (**bold**) column and then use enter to select the option and **↓** to step through the option selections to the right. Press enter again to select the new option. If a key is not pressed within 10 seconds the company name will be displayed and the backlight will turn off. For helpful Titan Tips, see page 16. I902 lists the programmable values for all settings

DEMA Engineering
St. Louis, MO

LANGUAGE	<i>Idioma</i>	<i>Idioma</i>	<i>Langue</i>
ENGLISH	<i>Portugues</i>	<i>Espanol</i>	<i>Francais</i>

↓

DETERGENT PRIME*	➔	<i>DET. PRIME PRIMING</i>	<i>DET. PRIME STOPPED</i>
-------------------------	---	---------------------------	---------------------------

↓

RINSE PRIME*	➔	<i>RINSE PRIME PRIMING</i>	<i>RINSE PRIME STOPPED</i>
---------------------	---	----------------------------	----------------------------

↓

SANITIZER PRIME*	➔	<i>SANITIZER PRIMING</i>	<i>SANITIZER STOPPED</i>
-------------------------	---	--------------------------	--------------------------

* A default timer of two minutes will stop the pump if it is not stopped manually.

↓

DET SP INPUT ***	➔	<i>DETERGENT STATUS DISPLAY</i>	
-------------------------	---	---------------------------------	--

*** See explanation on page 13.

↓

RACK COUNT 00000		<i>(This is a view only record.) 0-49999</i>	
-------------------------	--	--	--

↓

DESCALE	➔	<i>DESCALE</i>	
ENTER TO START **		<i>ENTER TO STOP</i>	

** Pressing enter inhibits all dispenser functions for three cycles for a door machine or until the detergent trigger becomes inactive after three minutes accumulated run time for a conveyor machine. Pressing ENTER during the de-scale cycle will terminate the de-scale mode.

↓

NEW PROGRAM *	➔	<i>SYSTEM ACCESS</i>	<i>(SYSTEM ACCESS cannot be entered until after NEW PROGRAM is completed)</i>
----------------------	---	----------------------	---

*This option will only be displayed if the dispenser has not been programmed the first time. If no key is pressed for two minutes, NEW PROGRAM mode will be exited, the company logo will be displayed, and all entries will be saved.

CONTROL MODE	<i>CONTROL MODE</i>	<i>CONTROL MODE</i>	
AUTO SWITCHOVER	<i>CONCENTRATION</i>	<i>PROBELESS</i>	

↓

***Auto Switchover set-up requirements:** for auto switchover to function properly the following must be done correctly.

1. Turn on Auto Switchover.
2. Program the set point for concentration (probe) mode.
3. Program **legitimate** probeless mode settings.

Legitimate probeless settings simulate titration results achieved in probe mode.

Initial Charge – amount of time (in sec) needed to reach a simulated set point with a clean tank

Recharge Time – amount of time (in sec) needed to maintain a simulated set point (top off)

Dwell/Door – how often to recharge, dwell is for conveyor mode and door is for machine operations in door mode.

4. Alarm Delay – must be set for less than 2 times the initial charge. Recommended setting at 80% of 2 times the initial charge.

Example: If initial charge is 1 min or 60 sec then the recommended alarm delay is 1 min, 36 sec or 96 sec (60 sec x 2 x .8).

SWITCHOVER ALARM ➔
INACTIVE

SWITCHOVER ALARM (This allows a message to be displayed if Auto Switchover is enabled and the control switches from concentration to probeless. Setting it to inactive will inhibit the display.)
ACTIVE



SERVICE
DISPENSER SOON

SWITCH MESSAGE (This allows the entry of a custom message to be displayed when a switch over occurs. Pressing Enter displays the current message and allows it to be changed, letter by letter, with the UP ↑ and DOWN ↓ keys.)

MACHINE TYPE ➔
CONVEYOR

MACHINE TYPE (This allows the selection of Door or Conveyor mode. The status may only be changed in Programming mode. Conveyor is the default.)
DOOR

TRIGGER MODE ➔
DETERGENT/RINSE

TRIGGER MODE **TRIGGER MODE** **TRIGGER MODE**
NO TRIGGER INPUT **DETERGENT ONLY** **RINSE ONLY**

NOTE: Four trigger options are available. DETERGENT/RINSE allows the traditional two trigger input. RINSE ONLY, requires only a rinse trigger. Rinse functions operate normally and detergent functions occur during the rinse trigger when using RINSE ONLY trigger. When using RINSE ONLY trigger in PROBELESS mode, the wash trigger may be connected to the machine fill valve. When the fill valve becomes active, the initial charge will be dispensed during the fill cycle. (v1.3 and later) DETERGENT ONLY, requires only a detergent trigger. The detergent operates normally. In conveyor mode, the rinse runs with the trigger. In door mode, the rinse additive is dispensed following the loss of the detergent trigger. NO TRIGGER INPUT, will cause both the rinse and the detergent functions to run whenever there is power to the dispenser. DETERGENT/RINSE is the default mode.

DIRTY H2O ALARM ➔
INACTIVE

DIRTY H2O ALARM Press "ENTER" and input time to indicate how long dish machine should run before alarm sounds.* (1 hr. min – 4 hrs. max)
ACTIVE

* The dirty H2O alarm will 'reset' after the tank has been drained and refilled.

COMPANY NAME

DEMA Engineering
St. Louis, MO

← (Insert your company name here.)

NOTE: Pressing "ENTER" displays the current company name and allows it to be changed, letter by letter, with the ↑ and ↓ keys (press and hold down to 'fast cycle'). The empty 'space' is between the ← and ! symbols. Press Enter to save.

ALARM VOLUME
5 0 – 10

CONC. SET POINT (Concentration set point default is 50)
200 0 – 1000

FEED RATE (Controls the rate of approach to the set point to help control overshoot. The default is 5.)
5 1 – 10

ALARM DELAY (The time delay before a detergent alarm will sound in concentration mode. It starts when the concentration is below the set point and is not increasing. It may be set from 5 seconds to 10 minutes. The default setting is 5 minutes.)
00:20 mm:ss

FEED LIMIT (The time delay from when the concentration alarm starts until the detergent pump is stopped. It may be set from 5 sec to 10 min. The default is 10 min.)
10:00 mm:ss

RECHARGE TIME (This is the time detergent will be dispensed in probeless mode after the initial charge is dispensed. This time is not used in the no trigger door mode. It may be set from 1 sec to 5 min. The default is 1 second.)
00:01 mm:ss

(Either **DEAD CYCLES** or **DWELL TIME** will display depending on Machine Type selected earlier)

DEAD CYCLES 1 0-10	(Door machine only. Set for how many 'dead cycles' (or door closings) where no detergent is dispensed. Detergent will dispense on the first cycle <u>after</u> the last dead cycle. The default is 1 dead cycle.)
DWELL TIME 01:30 mm:ss	(Conveyor machine only. Set for how long the machine will run before adding a recharge. The default is 90 seconds.)

INITIAL CHARGE
00:20 mm:ss
(This is the dispense time of the initial charge in probeless mode. The time is triggered by a main dispenser power interruption, the rinse limit being reached, an open probe when the detergent alarm is active and detergent type is set to manual (v1.3 & later), or the charge clock time being reached. It may be set from 1 sec to 10 min. The default is 15 sec.)

CHARGE CLOCK
01:00 hh:mm
(Set this to how long the dish machine should be 'off' before an 'initial charge is dispensed. It may be from 5 minutes to 16 hours. The default is 1 hour.)
(Everything in this block is displayed in Probeless Mode only. Otherwise continue below the block.)

DETERGENT ALARM INACTIVE	<i>DETERGENT ALARM ACTIVE</i>		
DETERGENT TYPE LIQUID	<i>DETERGENT TYPE DRY</i>	<i>DETERGENT TYPE MANUAL</i>	
(Only displayed if alarm is active)			
Note: When detergent type is liquid, the alarm is active, and the control is set to probeless, use a DEMA 82.15.1 Low Level Probe connected to the probe input.			
	<i>DET. ALARM CAL. CAL WATER ENTER</i>	<i>DET. ALARM CAL. CALIBRATING</i>	
<i>DET. ALARM CAL. CAL CHEM ENTER</i>	<i>DET. ALARM CAL. CALIBRATING</i>	<i>DET. ALARM CAL. SUCCESSFUL</i>	<i>DET. ALARM CAL. FAILED</i>
<hr/>			
NOTE: The DETERGENT ALARM CALABRATION setting is only available when the control mode is set to <u>probeless</u> , the DETERGENT ALARM is active, and the <u>detergent type is dry</u> . This is used in conjunction with a 581E bowl with sensor connections. Pressing enter prompts the user to place the detergent capsule in the bowl with the lid on the capsule. When this is done pressing enter again causes water to be passed through the bowl so that the control can measure the base conductivity. A calibration message is displayed. The control then prompts the user to remove the lid from the chemical capsule and place it in the bowl. Pressing enter again dispenses chemical so that the dispenser can measure the conductivity of the chemical/water mix. A calibration message is displayed. If the two readings are sufficiently different, an alarm set point is calculated and a success message is displayed. If the readings are the same, a fail message is displayed and the alarm is set to inactive.			
**The unit will ask for a set point to be entered. The set point should be somewhere between the concentration of clean water and a full charge. It is recommended to be about 75% of the concentration at full charge. If the concentration at full charge is 400, then it would be recommended to set the set point at 300.			

RINSE SPEED
50 0 – 100%
(The speed of the rinse motor may be set from 0 to 100. The motor runs during during adjustment. The default is 50.)

RINSE DELAY
0 0 – 15s
(This is the time from when a rinse trigger is received until the rinse pump starts. It may be set from 0 seconds to 15 seconds. The default is 0 sec.)

RINSE LIMIT
-- 15 – 70s
(This is the maximum time the rinse pump will be allowed to run. If the limit is active and reached, it will cause the next charge in probeless mode to be an initial charge. It may be set from 15 sec. to 30 sec. Advancing beyond 30 sec. causes the rinse limit to be inactive. The default for door machines is 18 seconds. The default for conveyor machines is inactive.)

RINSE LENGTH
12 5 – 75s

(The length of the rinse cycle for one rack. In a conveyor machine this is used for the Rack Counter. Every time the rinse runs for this time a rack is counted. In a door machine using only a detergent trigger, this is the length of the rinse cycle following the loss of the trigger. The default is 12 seconds.)

SANITIZER SPEED
5 0 – 100%

(The sanitizer speed may be set from 0 to 100. The sanitizer pump is active during adjustment. Setting the speed to 0 will cause other sanitizer settings to be skipped and the prime function will not be available.)

SANITIZER MODE
RUN WITH RINSE

SANITIZER MODE
RUN WITH DET.

ENTER NEW CODE

ENTER PROG CODE ← LEFT ACCEPTS 0000 NEW CODE SAVED
0000 OTHER TO REJECT

COMMENTS AND CLARIFICATIONS

SYSTEM ACCESS

This option will only be displayed if the dispenser has already been programmed. Press ENTER. You will be prompted for an access code. If no key is pressed for 30 minutes, SYSTEM ACCESS mode will be exited, the company logo will be displayed and all entries will be saved.

Code Reset

This is not a menu option and cannot be done from the keypad. If, for any reason, the codes are forgotten, the access codes can be cleared. Turn the power to the dispenser off. Open the front cover of the dispenser. Take the four screws out to lift the board out. There are two solder points on the back of the board. Connect them together with an insulated wire and turn on the power. Next, turn the power back off. Remove the connection from the two solder points. When the power is turned back on, the prompts will ask for a NEW PROGRAM. All of the program previously input will be retained. When the Programming code is requested, it will default to 0000 and may be reentered.

NOTE: All previous programs will NOT be erased.

Press ◀ at any of the submenu options to get to the System Access Menu.

External Alarm, (Aux. Alarm)

There are two .250" (6.4mm) spade terminals on the left side of the control board. There is a 24VDC output for an external alarm (buzzer, relay, etc.). (+) is the top terminal, (-) is the bottom terminal.

When sitting idle, the control will display the company logo with the backlight off. When triggers are received, they will be displayed with the backlight on for five seconds and then replaced with the company logo. The trigger message(s) will be replaced with any alarm messages if alarms occur. The alarm messages will remain, with the backlight on, until the alarms are cleared. An audible alarm will sound if there is an alarm condition and a trigger is present. Pressing any key will mute the alarm until the next trigger. The alarm will automatically mute when triggers are lost.

Modify Programming (System Access)

For helpful Titan Tips, see page 16. I902 also has all programmable values for all settings listed.

NOTE: TO MODIFY PROGRAMMING, PRESS ENTER ON THE OPTION NEEDING MODIFICATION, USE THE ARROWS TO GET TO THE SELECTION DESIRED THEN PRESS ENTER TO ACCEPT CHANGES.

DEMA Engineering
St. Louis, MO

LANGUAGE	<i>Idioma</i>	<i>Idioma</i>	<i>Langue</i>
ENGLISH	<i>Portugues</i>	<i>Espanol</i>	<i>Francais</i>

DETERGENT PRIME * *DET. PRIME PRIMING* *DET. PRIME STOPPED*
 * A default timer of two minutes will stop the pump if it is not stopped manually.

RINSE PRIME * *RINSE PRIME PRIMING* *RINSE PRIME STOPPED*

SANITIZER PRIME * *SANITIZER PRIMING* *SANITIZER STOPPED*

DET SP INPUT *** *DETERGENT STATUS DISPLAY*
 *** See explanation on page 13.

RACK COUNT 00000 0-49999

DESCALE *DESCALE*
ENTER TO START ** *ENTER TO STOP*

** Pressing enter inhibits all dispenser functions for three cycles for a door machine or until the detergent trigger becomes inactive after three minutes accumulated run time for a conveyor machine. Pressing ENTER during the de-scale cycle will terminate the de-scale mode.

SYSTEM ACCESS (NOTE: **SYSTEM ACCESS** cannot be entered until after **NEW PROGRAM** is completed.)

SYSTEM ACCESS allows you to enter any of the below listed parameters.

DISPENSER SET UP
PARAMETERS

NOTE: To see what is listed under each of these parameters, or to go directly to a parameter, look for the parameter listed in bold in a heading block below such as this one.

CONCENTRATION
PARAMETERS

**DISPENSER SET UP
PARAMETERS**

PROBLESS
PARAMETERS

Press the enter button, then you can step ↓ through everything under the heading block and ‘fine tune’ the date that was initially programmed under **NEW PROGRAM**.

RINSE CONTROL
PARAMETERS

SANITIZER SET UP
PARAMETERS

DIAGONSTIC MODE

END PROGRAMMING
PRESS ENTER

ENTER CODE
0000

PROGRAMING MODE

DISPENSER SET UP
PARAMETERS

RACK COUNT
00002

RACK COUNT
LEFT TO RESET

For the following sections, check the initial programming section for detailed accounts of what these settings indicate. This section will be for reference of the change in order of some of the settings. If detailed information is desired on a topic, please check the initial programming section for that topic.

CONTROL MODE *CONTROL MODE* *CONTROL MODE*
AUTO SWITCHOVER *CONCENTRATION* *PROBLESS*

***See Page 6 for specific instructions for Auto Switchover**

SWITCHOVER ALARM *SWITCHOVER ALARM* *SWITCH MESSAGE*
INACTIVE *ACTIVE*

MACHINE TYPE *MACHINE TYPE*
CONVEYOR *DOOR*

TRIGGER MODE *TRIGGER MODE* *TRIGGER MODE* *TRIGGER MODE*
DETERGENT/RINSE *NO TRIGGER INPUT* *DETERGENT ONLY* *RINSE ONLY*

NOTE: Four trigger options are available. DETERGENT/RINSE allows the traditional two trigger input. RINSE ONLY, requires only a rinse trigger. Rinse functions operate normally and detergent functions occur during the rinse trigger. DETERGENT ONLY, requires only a detergent trigger. The detergent operates normally. In conveyor mode, the rinse runs with the trigger. In door mode, the rinse additive is dispensed following the loss of the detergent trigger. NO TRIGGER INPUT will cause both the rinse and the detergent functions to run whenever there is power to the dispenser. DETERGENT/RINSE is the default mode.

DIRTY H2O ALARM ➔ *DIRTY H2O ALARM*
INACTIVE *ACTIVE*

COMPANY NAME DEMA Engineering
St. Louis, MO

NOTE: Pressing "ENTER" displays the current company name and allows it to be changed, letter by letter, with the **↑** and **↓** keys (press and hold down to 'fast cycle'). The empty 'space' is between the **←** and **!** symbols. Press to save.

ALARM VOLUME
2 0-10

ENTER NEW CODE *ENTER USER CODE* *← LEFT ACCEPTS 0000 NEW CODE SAVED*

RETURN TO **←**
SYSTEMACCESS

CONCENTRATION
PARAMETERS

CONC. SET POINT
398 0 – 1000

FEED RATE
5 1 – 10

ALARM DELAY (5 seconds to 10 minutes)
02:00 mm:ss

FEED LIMIT (5 seconds to 10 minutes)
10:00 mm:ss

RETURN TO SYSTEM ACCESS ←

PROBELESS PARAMETERS

RECHARGE TIME (1 second to 5 minutes)
00:01 mm:ss

(Either **DEAD CYCLES** or **DWELL TIME** will display depending on whether DOOR or CONVEYOR was selected earlier under MACHINE TYPE)

DEAD CYCLES 1 0-10	(Door machine only.)
DWELL TIME 01:30 mm:ss	(Conveyor machine only.)

INITIAL CHARGE (1 second to 10 minutes)
00:15 mm:ss

CHARGE CLOCK (10 minutes to 16 hours)
01:00 hh:mm

(Everything in this block is displayed in Probeless Mode only. Otherwise continue below the block.)

DETERGENT ALARM INACTIVE	<i>DETERGENT ALARM ACTIVE</i>	<i>DETERGENT ALARM MANUAL</i>	
DETERGENT TYPE LIQUID	DETERGENT TYPE DRY		
Note: When detergent type is liquid, the alarm is active, and the control is set to probeless, use a DEMA 82.15.1 Low Level Probe connected to the probe input.			
	<i>DET. ALARM CAL. CAL WATER ENTER</i>	<i>DET. ALARM CAL. CALIBRATING</i>	
<i>DET. ALARM CAL. CAL CHEM ENTER</i>	<i>DET. ALARM CAL. CALIBRATING</i>	<i>DET. ALARM CAL. SUCCESSFUL</i>	<i>DET. ALARM CAL. FAILED</i>

RETURN TO SYSTEM ACCESS ←

RINSE CONTROL PARAMETERS

RINSE SPEED
50 0 – 100%

RINSE DELAY
1 0 – 15s

RINSE LIMIT
-- 15 – 70s

RINSE LENGTH (The length of the rinse cycle for one rack.)
12 5- 75s

RETURN TO
SYSTEM ACCESS



**SANITIZER SET UP
PARAMETERS**

SANITIZER SPEED

5 0 – 100%

**SANITIZER MODE
RUN WITH RINSE**

*SANITIZER MODE
RUN WITH DET.*

RETURN TO
SYSTEM ACCESS



DIAGNOSTIC MODE

(No alarms are active in DIAGNOSTIC MODE. The control functions will operate normally.)

DET SP INPUT
C + 0398 0000

(This screen displays the detergent status. The first character in the second line is “P” if the dispenser is in probeless mode and “C” for concentration mode. The next character is only displayed when a trigger is present. When a trigger is present “I” is displayed during an initial charge, “D” during a dwell or dead cycle, “T” during a recharge, “+” when the pump is running in concentration mode, or “-“ when the pump is not running during concentration mode. The next number is the set point in concentration mode or the alarm point in probeless mode. The other number is the detergent sensor or probe reading.)

FEED OVER UNDER
0000 0000

FEED OVER UNDER (**See NOTE)
LEFT TO RESET

PROBE OPEN SHORT
0000 0000

PROBE OPEN SHORT (***)See second NOTE)
LEFT TO RESET

RETURN TO
SYSTEM ACCESS



**** NOTE:** This screen displays the total switchover count for OVER and UNDER feedings. The number below OVER is the count of switchovers caused by the dispenser feeding more than twice the INITIAL CHARGE time without reaching the set point. The number below UNDER is the count of switchovers caused by the concentration remaining above the set point for more than four times the DWELL TIME or DEAD CYCLES. The OVER count is usually caused by a “scaled” probe, a leaky drain, a leaky water supply valve, or excessive splashing of rinse water into the wash tank. The UNDER count is most often caused by no make up water being added or extreme wash tank contamination (very high soil load). A large number of counts in either of these areas are a reason to review the dispenser setup especially the PROBELESS Parameters.

***** NOTE:** This screen displays the total switchover counts for an open probe or a shorted probe. Note that a probe must be shorted for at least 30 seconds before it is counted. This gives the short (usually flatware) time to clear. An open probe counts immediately.

**END PROGRAMMING?
PRESS ENTER**

Helpful Tips on the Titan Warewash System

Inductive Probe (82.28.1): The inductive probe is particularly useful for situations where the C-12VIK probe is experiencing considerable scale build up. The inductive probe is not affected by the scale build-up that the C-12VIK would experience in a typical wash tank and does not need regular cleaning. There is also a temperature adjustment feature on the probe that can be set to change the amount of soap for the temperature of the water. See instruction sheet I-889 for more information.

Magnetic Field Sensors (82.23.1): If trigger connection points cannot be established, the magnetic field sensors (82.23.1) may be used in place of the trigger board and trigger wires. The magnetic field sensors connect directly to the control board as shown on the wiring diagram. The magnetic field sensors can be placed on wash motors or rinse valves to measure a magnetic field when the motors or valves are activated which will trigger the proper pump or valve on the dispenser. See instruction sheet I-888 for more information.

Product Alarm Sensors: The product alarm sensors are non-contact sensors to detect out of product conditions on the detergent, rinse, and/or sanitizer. These sensors are plugged into the appropriate connectors at the bottom of the control board. No programming or calibration is required. The detergent alarm sensor functions in addition to any other alarm conditions.

Auto Switchover: This feature allows for the automatic switching from Concentration to Probeless in the case of a probe fault or inconsistent concentration readings. Conditions that can activate this feature are: (1) An Open Probe; (2) A Closed Probe; or (3) Detergent not feeding properly, too much or too little detergent. The Titan will automatically switch back to concentration once it detects proper probe conditions.

An OPEN probe is when a probe wire is disconnected or there is lime buildup on the tips of the probe. This will cause an Auto Switchover. A CLOSED probe is when something for example, a piece of flatware, may be lying across the probe tips. The Titan will wait 30 seconds to see if the short will clear. This will cause an Auto Switchover.

If the Titan is reading an increase in detergent strength and does not reach set point in twice the time of the initial charge setting for probeless mode, then the Titan will Auto Switch to probeless mode. (**Note: Factory default for this initial charge is 15 seconds. This may not be enough time for the wash tank to reach its concentration level. Watch the wash tank reach its level and determine the time it takes, then use this as the setting for the initial charge in probeless to help from using the Auto Switchover feature when not necessary**). This is an OVER feed condition. This is usually caused by a partially scaled probe, a leaking drain, a leaking water supply valve, or excessive splashing of rinse water into the wash tank. This over feed condition is usually caused by excessive wash tank dilution.

If the Titan is reading an excessive amount of detergent in the wash tank and the input is not lowering to the set point in either 8 times the dwell time for conveyor mode or four times the dead cycles in door mode, then the Titan will Auto Switch to probeless mode. (**Note: The factory default for dwell time is 90 seconds and for dead cycles is 1**). This is an UNDER feed condition. This is usually caused by no make up water being added or extreme wash tank contamination (very high soil load or washing salt shakers).

Feed Rate: Another possible cause of unnecessary Auto-Switchover is that the feed rate is not properly adjusted for the tank size or feeding location. The purpose of the feed rate in concentration mode is to initially charge the tank to obtain the set point without excessive over shoot. Factory Titans are set for a feed rate of 5 which is about a 4 second feed and a ½ second pause all the way to the set point. If the feed rate is too high, it will over charge the wash tank and if the input does not return to the set point in 4 times the dwell time or dead cycles, the Titan switches to probeless mode. To minimize this, set the feed rate as low as possible to achieve the initial charge as close to the set point as possible. Water temp, pressure, discharge tube length, and probe placement can affect this feed time as well.

Alarm Delay – There are several detergents that are used by chemical companies that do not mix well with water and will drop out of solution and settle at the bottom of the tank. When the machine is cycled again, the Titan will read the higher concentration solution and turn the alarm delay off. It will then see no increase in concentration, since the INPUT reading is below the set point. This is not a defect in the unit. It is due to the detergent. The Alarm Delay setting should be changed to a few seconds before the end of the cycle to insure it will alarm.

When in Auto Switchover, the alarm delay should be set for less than 2 times the initial charge time or approximately 80% of two times the initial charge time.

Troubleshooting

Symptom	Probable Cause	Remedy
No power is being supplied to the unit	<ol style="list-style-type: none"> 1. Trigger Cables connected to the wrong place on the machine. 2. Switch on bottom of unit is turned off. (Some units may not have a switch) 3. Power is not cycling on the machine properly. 4. Trigger/Power cable is damaged from installation. 	<ol style="list-style-type: none"> 1. Check wiring diagram for proper connection and contact dish machine manufacturer for correct trigger placement. 2. Make sure switch is turned on. 3. Check with the dish machine manufacturer if all power should have been restored to the unit to see if there is an issue with the machine. 4. Turn power to the dish machine off and inspect the cable for any possible damage done.
Pumps are not priming like they should be or not holding a prime	<ol style="list-style-type: none"> 1. Hole in the tubing from the chemical container to the pump head. 2. Hole in the squeeze tube in the pump head. 3. Fitting is not tight on the tubing 	<ol style="list-style-type: none"> 1. Check the tubing from the chemical container to the pump head for leaks by feeling the tubing for chemical that has leaked out. Replace the tube if necessary. 2. Replace the squeeze tube after inspecting it for a possible hole or leak. 3. Check both the inlet and outlet fitting and tighten if necessary to create a good seal.
Pump over feeding	<ol style="list-style-type: none"> 1. If in concentration or probe mode, feed rate may not be set correctly. 2. If in concentration or probe mode, probe cable may not be connected properly. 3. If a probe is being used, scale could be built up on the probe. 4. Range of set point is too low. 	<ol style="list-style-type: none"> 1. Check the programming for the feed rate. 2. Check the probe cable connection points and make sure it is connected properly. 3. Clean Probe. 4. Check set point in programming.
Pump under feeding	<ol style="list-style-type: none"> 1. If in concentration or probe mode, the probe cable may be shorted. 2. If a probe is being used, scale would be build up on the probe. 3. Range of set point is too high. 	<ol style="list-style-type: none"> 1. Check the probe cable for any possible shorts and correct the issue where necessary. 2. Clean Probe. 3. Check set point in programming..
Rinse/Sanitizer pump not running	<ol style="list-style-type: none"> 1. Speed turned off. 	<ol style="list-style-type: none"> 1. Check the programming to see the speed setting and make sure it is on the proper setting.

Warranty

Merchandise Returns

No Merchandise will be Returned for Credit Without DEMA'S Written Permission. Returned Merchandise Authorization Number is Required in Advance of Return.

Product Warranty

DEMA products are warranted against defective material and workmanship under normal use and service for one year from the date of manufacture. This limited warranty does not apply to any products that have a normal life shorter than one year or failure and damage caused by chemicals, corrosion, physical abuse, or misapplication. Rubber and synthetic rubber parts such as "O"-rings, diaphragms, PVC tubing, and gaskets are considered expendable and are not covered under warranty. This warranty is extended only to the original buyer of DEMA products. If products are altered or repaired without prior approval of DEMA, this warranty is void. Defective units or parts should be returned to the factory with transportation prepaid. If inspection shows them to be defective, they will be repaired or replaced without charge, F.O.B. factory. DEMA assumes no liability for damages. Return merchandise authorization number must be granted in advance of returned units for repair or replacement (See "Merchandise Returns" above).