

DEMA Nitro

Ware Wash Chemical Dispensing

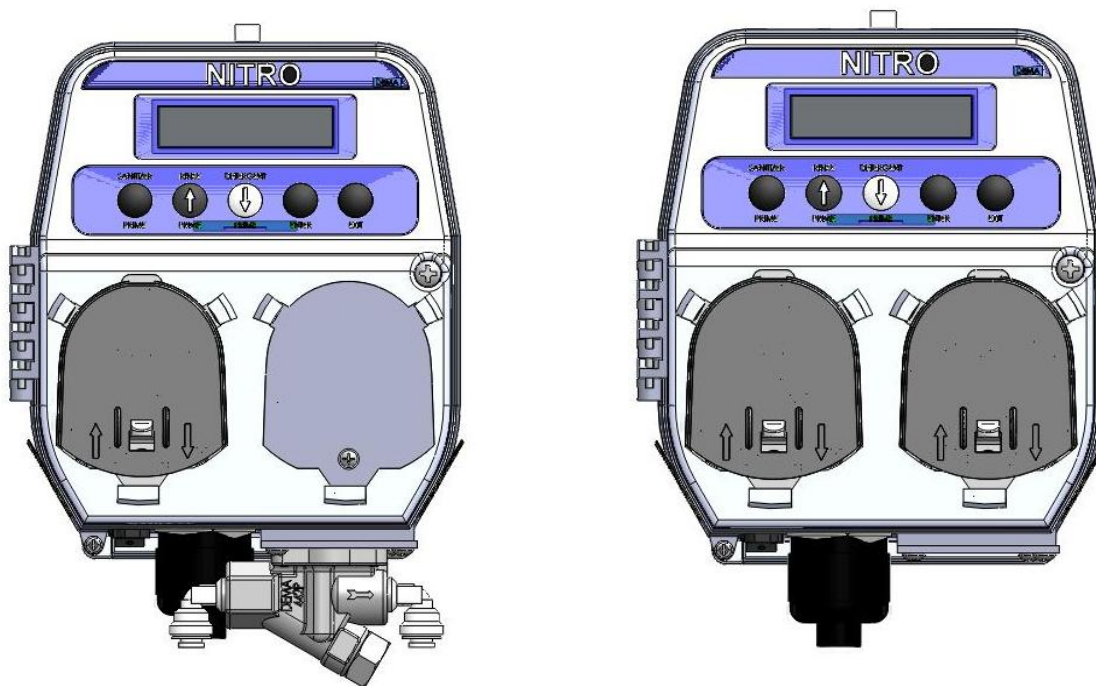

Overview

The DEMA® Nitro is a digital ware wash dispenser designed to dispense cleaning chemicals into ware wash and dish machines. The unit is triggered by a ware wash machine. The Nitro is programmed via the front panel.

Warnings



Installation of DEMA products must meet all applicable electrical codes and regulations established by national, city, county, parish, provincial or other agencies. It is possible that electrical codes and regulations require that a certified electrical contractor or engineer perform the electrical installation. For questions, contact a certified electrician.



All installations must conform to local plumbing codes and use approved backflow prevention devices. A pressure indicating tee is to be installed with existing faucets according to local plumbing codes in the state of Wisconsin and any other state that requires the use of a pressure indicating tee.

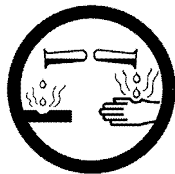

ALWAYS WEAR PROTECTIVE CLOTHING AND EYEWEAR WHEN WORKING WITH CHEMICAL PRODUCTS.

Packing List

X = included in kit

Part Number	Description	N.DL.TA	N.LL.TA	N.DLL.TA	N.LLL.TA
904.8T	RINSE CHECK VALVE ¼" OD TEFLON BALL	X	X	X	X
80.55	LIQUID DETERGENT FEED INJECTION ELBOW		X		X
81.312.1	SPLIT PICK UP TUBE STIFFENER	1	2	2	3
25.68.20	20 FT ¼" OD LDPE TUBING	X	X	X	X
C.12B	CONDUCTIVITY CELL	X	X	X	X
100.12.SV1	VINYL RINSE TUBING	X	X	X	X
58.5	OVERFLOW ELBOW KIT – DRY DETERGENT	X		X	
904.8KY	RINSE CHECK VALVE ¼" COMP X 1/8" NPT KYNAR			X	X
81.16.1	TIE WRAPS 8" LONG	5	5	8	8
I980	INSTRUCTION SHEET	X	X	X	X

Operational Requirements

For indoor use only	
Main Power	100-265VAC 50/60 Hz 1.5A
Trigger Inputs	24-480 V 50/60 Hz
Motor/Solenoid Rating	24VDC
Enclosure Material	ABS
Environmental Temp.	0-40°C 32-104°F
Product Weight	1.8 kg 4 lbs
The integrity and operational characteristics of this unit are not guaranteed outside the above mentioned parameters. Use of this unit outside of these parameters nullifies warranty.	

Overall Size

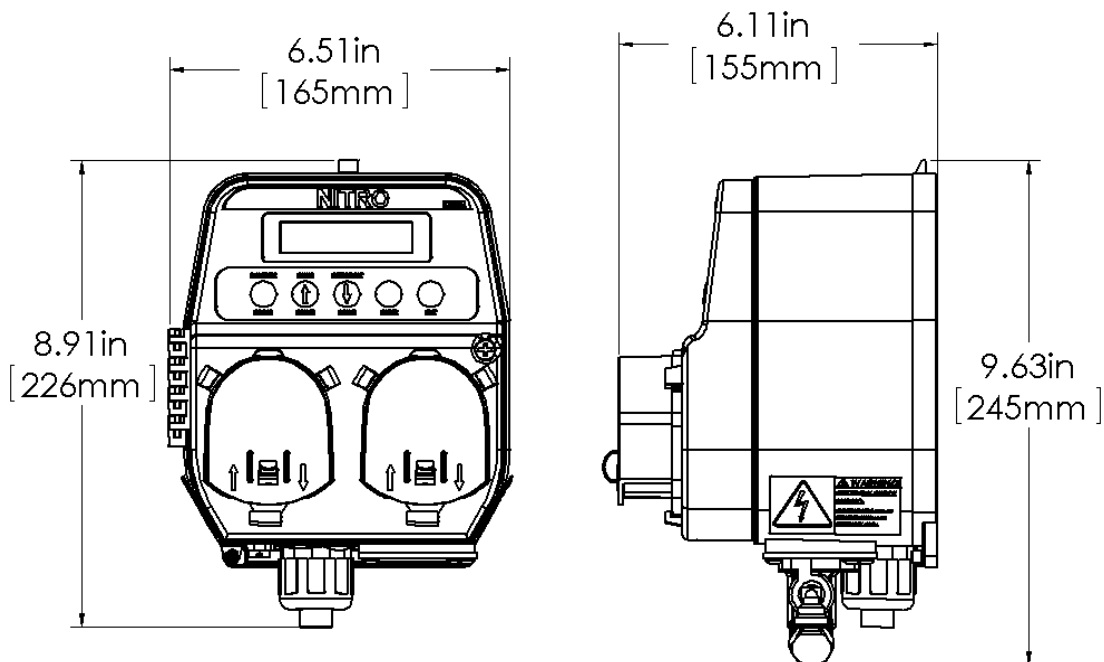

Replacement Parts List

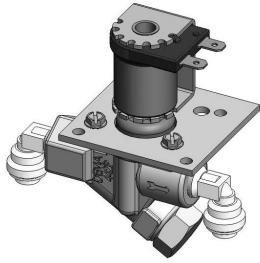

**81.316.6 NITRO/NITRO EXPRESS
DETERGENT VALVE CONVERSION
AND REPLACEMENT KIT
58.104.2 – J.G. ELBOW FITTING**

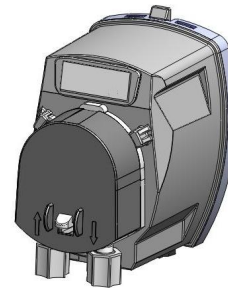

**O.ADC NITRO/NITRO EXPRESS
SANITIZER PUMP WITH TUBING
AND ACCESORIES**

Model shown is of an N.LL.TA

NO.	KIT NO.	DESCRIPTION
1	81.316.1	NITRO/NITRO EXPRESS POWER SUPPLY REPLACEMENT KIT
2	81.316.12	NITRO CONTROL BOARD REPLACEMENT
3	81.316.4	NITRO/EXPRESS DETERGENT PUMP HEAD & MOTOR CONV OR REPLACEMENT KIT
	81.316.10	NITRO/NITRO EXPRESS DETERGENT MOTOR ONLY REPLACEMENT KIT
	81.316.6	NITRO/NITRO EXPRESS DETERGENT VALVE CONVERSION AND REPLACEMENT KIT
4	81.316.5	NITRO/NITRO EXPRESS RINSE PUMP HEAD AND MOTOR REPLACEMENT KIT
	81.316.11	NITRO/NITRO EXPRESS RINSE MOTOR ONLY REPLACEMENT KIT
5	81.316.8	NITRO/NITRO EXPRESS DETERGENT PUMP HEAD ONLY REPLACEMENT KIT
	81.316.9	NITRO/NITRO EXPRESS RINSE PUMP HEAD ONLY REPLACEMENT KIT
	25.21.4	SINGLE SQUEEZE TUBE REPLACEMENT KIT
	25.21.5	BULK (5) SQUEEZE TUBE REPLACEMENT KIT
6	L1113	MEMBRANE LABEL
7	81.275.1	MOUNTING BRACKET
8	81.118.11.2	TRIGGER BOARD REPLACEMENT KIT (BOARD ONLY)
	81.118.11.4	TRIGGER WIRE SOURCE TO BOARD KIT (WIRE ONLY)
	82.23.1	MAGNETIC FIELD READER, FLUX SENSOR KIT (NOT SHOWN) see page 4 for info
9	82.28.1	INDUCTIVE PROBE KIT (NOT SHOWN) see page 5 and 6 for more info

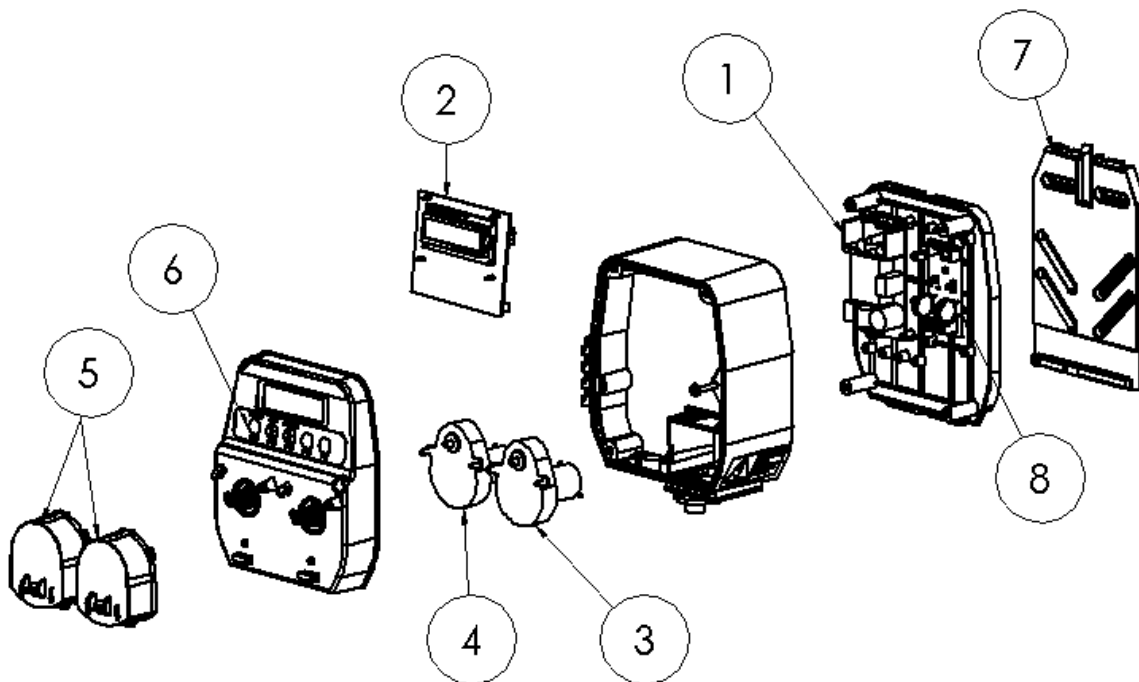

Installation



WARNING: INSTALLATION OF DEMA PRODUCTS MUST MEET ALL APPLICABLE ELECTRICAL CODES AND REGULATIONS ESTABLISHED BY NATIONAL, CITY, COUNTY, PARISH, PROVINCIAL OR OTHER AGENCIES. IT IS POSSIBLE THAT ELECTRICAL CODES AND REGULATIONS REQUIRE THAT A CERTIFIED ELECTRICAL CONTRACTOR OR ENGINEER PERFORM THE ELECTRICAL INSTALLATION. FOR QUESTIONS, CONTACT A CERTIFIED ELECTRICIAN.

ALL ELECTRICAL POWER MUST BE TURNED OFF TO THE HEATING ELEMENTS AND DISH MACHINE PRIOR TO BEGINNING INSTALLATION

UNIT MUST BE GROUNDED (EARTHED).

Mounting the Nitro

1. Remove mounting bracket from dispenser.
2. Mount the bracket in an appropriate place on a wall.
3. Slide the dispenser onto the bracket and attach the secure screw on the bottom left corner of the dispenser.

Setting up the Nitro and the Dish Machine

1. Locate the electrical connection point. The input power may be 100V – 265 V 50/60 Hz. Check with the manufacturer of the machine to determine if there are dedicated terminals available for installation.
2. Properly ground the dispenser to earth ground.
3. If the Nitro will be operating in the concentration mode, locate the proper position for the DEMA C-12B probe or the DEMA Inductive Probe (82.28.1) in the wash tank. The probe must be installed below the water level, normally 1-2” from the bottom of the tank, and must be kept away from heating elements, pump intake, drains and incoming water supply.
4. Install the detergent injection bulkhead fitting (80-55) above the probe (if a probe is used) to obtain a rapid reading of all chemicals entering the wash tank.
5. Install the rinse line injection fitting (904-8T) into the rinse line tap provided by the manufacturer of the machine. If a tap is not provided, follow the manufacturer’s recommendations for installing this fitting.
6. Install the sanitizer injection fitting (904-8KY) (if sanitizer is used) into the rinse line tap provided by the manufacturer of the machine. If a tap is not provided follow the manufacturer’s recommendations for installing this fitting.

Connecting the Chemical Tubing to the Nitro

1. After mounting the dispenser, measure the length of tubing needed to go from the dispenser to the chemical containers. The detergent tubing (25.68.20) is opaque in color and has a larger inside diameter than the rinse and sanitizer tubing (100.12.SV1) which is clear in color and has a small inside diameter.
2. Cut the tubing to the length required and, if desired, place the pickup tube on the tubing before placing in the chemical container.
3. Measure the length of tubing needed to go from the dispenser to the chemical injection point on the machine.
4. Cut the tubing to the length required to reach the bulkhead fitting or chemical injection point on the machine.

Clasp Close Pump Heads

The pump heads have an added feature which will help to ensure the pump head is installed properly. When pushing the pump head on be sure to see the clip is fully covering the notch as seen in the first picture. If the tab is not fully engaged, there is a possibility of it popping off the pump head as seen in the second picture.



Wiring the Nitro to the Dish Machine

The following diagram is included to help to install the wires in the correct places for proper power for the unit.

WARNING: For safety purposes disconnect main power to the dish machine before wiring trigger signals to the Nitro. Connect power to the Nitro per the dish machine manufacturer’s recommendations.

UNIT MUST BE GROUNDED (EARTHED).



The following steps will help to insure the proper wiring of the unit. The unit should be triggered to power on from the dish machine that it is being used in conjunction with. DEMA Engineering does not recommend powering the unit separately from the dish machine. The following steps will insure that the unit only receives power when it is necessary to have power to run the setup that is programmed in the unit.

Flux Sensors - If trigger connection points cannot be established, the magnetic field readers (82.23.1) may be used in place of the trigger board and cable. The magnetic field readers or flux sensors connect directly to the control board in the trigger wires spots as shown on the wiring diagram. The magnetic field readers or flux sensors can be placed on wash motors or rinse valves to measure a magnetic field when the motors or valves are activated which will trigger the proper pump or valve on the dispenser.

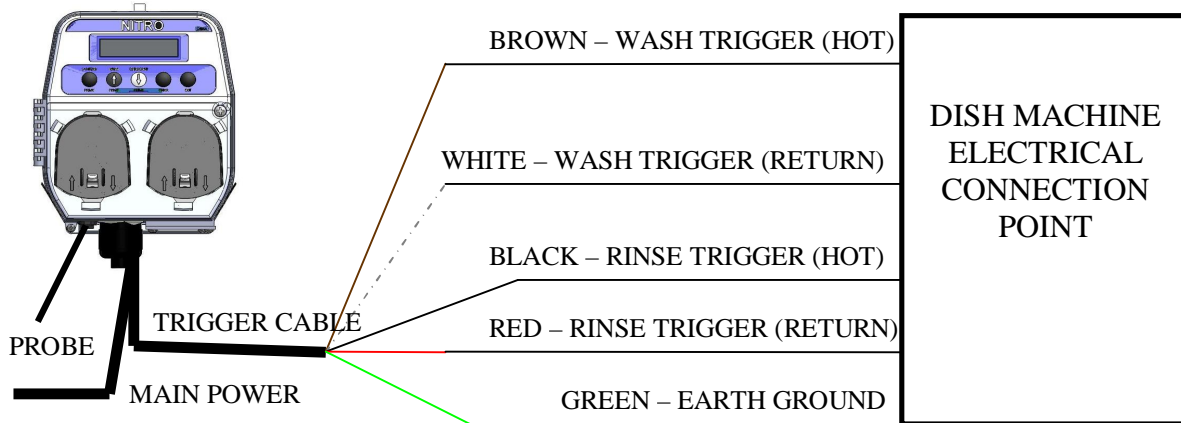

1. Connect the wash trigger (white and brown wires) to the appropriate wash trigger output (between 24 and 480 V 50/60Hz) as recommended by the dish machine manufacturer.
2. Connect the rinse trigger (black and red wires) to the appropriate rinse trigger output (between 24 and 480 V 50/60 Hz) as recommended by the dish machine manufacturer.
3. Make sure to connect the earth ground (green wire) to the ground connection on the dish machine as recommended by the dish machine manufacturer.

Main Power should be applied any time there is power to the dish machine. The main power cable will come out of the conduit fitting with the trigger cable and be hooked up near the same electrical connection point on the dish machine.

If there is ever any question about the main power or trigger cable connection to the dish machine, please check with the dish machine manufacturer to see where the proper trigger connection points are located before installing the trigger connection wires.

Below is a wiring diagram for the unit. This is the internal wiring of the unit.

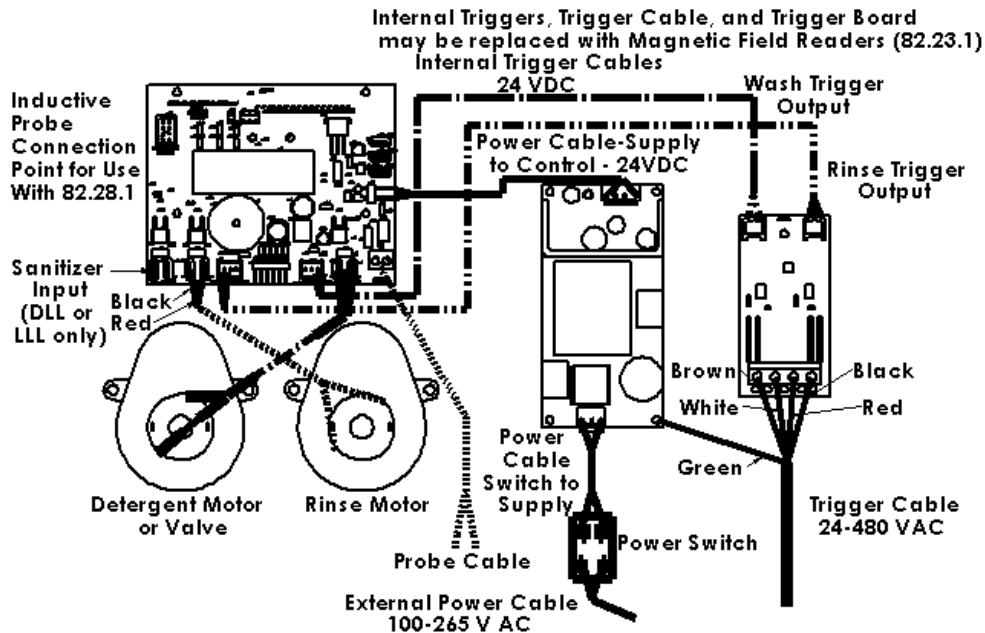

Initial Programming

The programming of this unit is done through the control board, display, and buttons on the front of the unit.
Programming of the unit is as follows:

Company Name	<i>Press and hold "Enter" Button for 3 Seconds until backlight comes on</i>				
Press ↓					
Language	<i>English, Spanish, French, Portuguese</i>				
Press ↓					
Rack Count	<i>Show Rack count</i>				
Press ↓					
Det. SP Input	<i>Det. C = Concentration or P = Probeless SP= Set point Input & probe reading</i>				
Press ↓					
New Program	<i>Press Enter</i>				
Control Mode	<i>Press Enter, then select using arrows Concentration (Probe) or Probe-less</i>				
Press ↓					
Machine Type	<i>Press Enter, then select using arrows Conveyor or Door.</i>				
Press ↓					
Trigger Mode	<i>Press Enter, then select Detergent/Rinse or Rinse Only or Detergent Only</i>				
Press ↓					
	When Concentration is chosen	When Probeless Door is chosen		When Probeless Conveyor is chosen	
Concentration Set Point	<i>0-1000</i>	Recharge Time	<i>1s – 5 min</i>	Recharge Time	<i>1s – 5min</i>
Press ↓		Press ↓		Press ↓	
Feed Rate	<i>0-10</i>	Dead Cycles	<i>0-5</i>	Dwell Time	<i>1s – 10 min</i>
Press ↓		Press ↓		Press ↓	
Feed Limit	<i>5s – 10 min</i>	Initial Charge	<i>1s – 10 min</i>	Initial Charge	<i>1s – 10 min</i>
Press ↓		Press ↓		Press ↓	
Alarm Delay	<i>5s - 10 min</i>	Charge Activate	<i>Off-60s</i>	Charge Clock	<i>5 min – 16 hrs</i>
Press ↓		Initial Charge Activate will determine the length of the rinse trigger that instigates an initial charge while in probe-less mode.		Charge Clock – If no triggers are received for this length of time, the next wash trigger will give an initial charge.	
Alarm Volume	<i>0-10</i>				
Press ↓					
Rinse Speed	<i>0-100%</i>				
Press ↓					
Rinse Delay	<i>0-15s</i>	<i>Door Mode Only</i>			
Press ↓					
Rinse Limit	<i>15s - 30s</i>	<i>Door Mode Only</i>			
Press ↓					
Rinse Length	<i>5s-75s</i>	<i>Conveyor and Door/Detergent Trigger only Modes</i>			
Press ↓					
Sanitizer Speed	<i>0-100%</i>				
Press ↓					
Company Name	<i>Press Enter, use arrows to change characters, use sanitizer prime and exit to move cursor left and right.</i>				
Press ↓					
Rack Count	<i>Press Enter, then Exit to Reset Rack Count</i>				
Press ↓					
Enter New Code	<i>Enter 4 digit code, use sanitizer prime button to move cursor</i>				
Press ↓					
Control Mode	<i>Reverts back to beginning of programming</i>				

Inductive Probe – With the inductive probe there are a several settings that can be further changed to help make the inductive probe more useful. For detailed information on those settings, please see instruction sheet I889 that comes with the Inductive Probe Kit (82.28.1). For further assistance contact DEMA Technical Service.

Modify Programming

When modifying the programming of the unit. Use the flow chart below for modifications. The menus change slightly when modifying the programming.

Company Name	<i>Press and hold "Enter" Button for 3 Seconds until backlight comes on</i>				
Press ↓					
Language	<i>English, Spanish, French, Portuguese</i>				
Press ↓					
Rack Count	<i>Show Rack count</i>				
Press ↓					
Det. SP Input	<i>Det. C = Concentration or P = Probeless SP= Set point Input & probe reading</i>				
Press ↓					
Modify Program	<i>Enter Code</i>				
When Concentration is chosen		When Probeless Door is chosen		When Probeless Conveyor is chosen	
Concentration Set Point	<i>0-1000</i>	Recharge Time	<i>1s – 5 min</i>	Recharge Time	<i>1s – 5min</i>
Press ↓		Press ↓		Press ↓	
Feed Rate	<i>0-10</i>	Dead Cycles	<i>0-5</i>	Dwell Time	<i>1s – 10 min</i>
Press ↓		Press ↓		Press ↓	
Feed Limit	<i>5s – 10 min</i>	Initial Charge	<i>1s – 10 min</i>	Initial Charge	<i>1s – 10 min</i>
Press ↓		Press ↓		Press ↓	
Alarm Delay	<i>5s - 10 min</i>	Charge Activate	<i>Off-60s</i>	Charge Clock	<i>5 min – 16 hrs</i>
Press ↓		Initial Charge Activate will determine the length of the rinse trigger that instigates an initial charge while in probe-less mode.		Charge Clock - If no triggers are received for this length of time, the next wash trigger will give an initial charge	
Alarm Volume	<i>0-10</i>				
Press ↓					
Rinse Speed	<i>0-100%</i>				
Press ↓					
Rinse Delay	<i>0-15s</i>	<i>Door Mode Only</i>			
Press ↓					
Rinse Limit	<i>15s - 30s</i>	<i>Door Mode Only</i>			
Press ↓					
Rinse Length	<i>5s-75s</i>	<i>Conveyor and Door/Detergent Trigger only Modes</i>			
Press ↓					
Sanitizer Speed	<i>0-100%</i>				
Press ↓					
Control Mode	<i>Press Enter, then select using arrows Concentration (Probe) or Probe-less</i>				
Press ↓					
Machine Type	<i>Press Enter, then select using arrows Conveyor or Door.</i>				
Press ↓					
Trigger Mode	<i>Press Enter, then select Detergent/Rinse or Rinse Only or Detergent Only</i>				
Press ↓					
Company Name	<i>Press Enter, use arrows to change characters, use sanitizer prime and exit to move cursor left and right.</i>				
Press ↓					
Rack Count	<i>Press Enter, then Exit to Reset Rack Count</i>				
Press ↓					
Enter New Code	<i>Enter 4 digit code, use sanitizer prime button to move cursor</i>				
Press ↓					
Control Mode	<i>Reverts back to beginning of programming</i>				

Troubleshooting

(Some models may not include all items listed below)

Symptom	Probable Cause	Remedy
No power is being supplied to the unit	<ol style="list-style-type: none"> 1. Trigger Cables connected to the wrong place on the machine. 2. Switch on bottom of unit is turned off. 3. Power is not cycling on the machine properly. 4. Trigger/Power cable is damaged from installation. 	<ol style="list-style-type: none"> 1. Check wiring diagram for proper connection and contact dish machine manufacturer for correct trigger placement. 2. Make sure switch is turned on. 3. Check with the dish machine manufacturer if all power should have been restored to the unit to see if there is an issue with the machine. 4. Turn power to the dish machine off and inspect the cable for any possible damage done.
Pumps are not priming like they should be or not holding a prime	<ol style="list-style-type: none"> 1. Hole in the tubing from the chemical container to the pump head. 2. Hole in the squeeze tube in the pump head. 3. Fitting is not tight on the tubing 	<ol style="list-style-type: none"> 1. Check the tubing from the chemical container to the pump head for leaks by feeling the tubing for chemical that has leaked out. Replace the tube if necessary. 2. Replace the squeeze tube after inspecting it for a possible hole or leak. 3. Check both the inlet and outlet fitting and tighten if necessary to create a good seal.
Pump over feeding	<ol style="list-style-type: none"> 1. If in concentration or probe mode, feed rate may not be set correctly. 2. If in concentration or probe mode, probe cable may not be connected properly. 3. If a probe is being used, scale could be built up on the probe. 4. Range of set point is too low. 	<ol style="list-style-type: none"> 1. Check the programming for the feed rate. 2. Check the probe cable connection points and make sure it is connected properly. 3. Clean Probe. 4. Check set point in programming.
Pump under feeding	<ol style="list-style-type: none"> 1. If in concentration or probe mode, the probe cable may be shorted. 2. If a probe is being used, scale would be build up on the probe. 3. Range of set point is too high. 	<ol style="list-style-type: none"> 1. Check the probe cable for any possible shorts and correct the issue where necessary. 2. Clean Probe. 3. Check set point in programming..
Rinse/Sanitizer pump not running	<ol style="list-style-type: none"> 1. Speed turned off. 	<ol style="list-style-type: none"> 1. Check the programming to see the speed setting and make sure it is on the proper setting.

Warranty

Merchandise Returns

No Merchandise will be Returned for Credit Without DEMA'S Written Permission. Returned Merchandise Authorization Number is Required in Advance of Return.

Product Warranty

DEMA products are warranted against defective material and workmanship under normal use and service for one year from the date of manufacture. This limited warranty does not apply to any products that have a normal life shorter than one year or failure and damage caused by chemicals, corrosion, physical abuse, or misapplication. Rubber and synthetic rubber parts such as "o"-rings, diaphragms, PVC tubing, and gaskets are considered expendable and are not covered under warranty. This warranty is extended only to the original buyer of DEMA products. If products are altered or repaired without prior approval of DEMA, this warranty is void.

Defective units or parts should be returned to the factory with transportation prepaid. If inspection shows them to be defective, they will be repaired or replaced without charge, F.O.B. factory. DEMA assumes no liability for damages. Return merchandise authorization number must be granted in advance of returned units for repair or replacement (See "Merchandise Returns" above).